*With ADAS Composite
Vehicle Type 1*



TEST INFORMATION
FOR THE
ADVANCED DRIVER ASSISTANCE SYSTEMS
(ADAS) SPECIALIST TEST (L4)

- ***Overview***
- ***Test Specifications***
- ***Task List***
- ***Sample Questions***
- ***Industry Training***

ADVANCED DRIVER ASSISTANCE SYSTEMS (ADAS) SPECIALIST TEST OVERVIEW

INTRODUCTION

The Advanced Driver Assistance Systems (ADAS) Specialist Test (L4) is an advanced level certification from ASE. It is geared toward technicians who diagnose, repair, and calibrate advanced driver assistance systems in modern automobiles and light trucks. To register to take the L4 certification test, you must have passed either the Automobile: Electrical/Electronic Systems (A6) certification test or the Collision: Mechanical and Electrical Components (B5) certification test.

The L4 test consists of 40 scored multiple choice questions and 10 unscored questions. (Upon initial release, it will consist of 80 total questions.) Half of the questions require the use of the *ADAS Composite Vehicle Reference*; these questions will be clearly identified on the test.

If you pass the L4 test and have at least three years of appropriate hands-on working experience (relevant training may substitute for some of the experience), you will be certified as an ASE Advanced Level Specialist.

Registration information is available at www.ase.com. Your myASE account gives you direct access to your personal ASE certification information, as well as the ability to register for and schedule tests.

WHO WRITES THE QUESTIONS?

Each question has its roots in an ASE question writing workshop where working technicians, service representatives from vehicle and engine manufacturers, aftermarket trainers, and technical educators meet to share ideas and translate them into test questions. Each question written by these experts must survive review by all members of the group. The questions deal with practical problems experienced by technicians in their work with vehicles that include advanced driver assistance systems.

After the question writing workshop, all questions are pre-tested and quality-checked on a national sample of technicians. Those questions that meet ASE standards of quality and accuracy are included in the scored sections of future tests; others are redrafted or discarded.

HOW DO I PREPARE FOR THE ASE L4 TEST?

To prepare for the test, **you need both this book and the *ADAS Composite Vehicle Reference*** (online at <https://ase.com/ase-study-guides>). We suggest that you follow these steps:

- Step 1.** Study the content areas of the Test Specification, noting how many questions each content area has on the test.
- Step 2.** Carefully read the Task List, noting the areas in which your skills are strong or weak. You can do this by marking each task that you do not perform often or do not understand completely.
- Step 3.** Practice with the sample questions that follow. Although these questions will not appear in the test, they are similar in style and difficulty to the actual test questions. Use the *ADAS Composite Vehicle Reference* on the questions that call for it.
- Step 4.** Use steps 1 through 3 to identify any skill areas where you need additional study or training. Then, use the Industry Training section (page 10) to find training help.

WHAT IS THE ADAS COMPOSITE VEHICLE TYPE 1 REFERENCE?

The L4 test will make use of the *ADAS Composite Vehicle Type 1 Reference*. **This reference will be available as an electronic pop-up document during the test; you will not receive a printed copy at the test center.** The *Composite Vehicle Reference* features descriptions of systems, components, calibration procedures, and wiring schematics that are included in the composite vehicle. You should review this document thoroughly before your test appointment. Download a copy from <https://ase.com/ase-study-guides>

In the test, questions that require use of the *Composite Vehicle Reference* are clearly identified. You will need to use the information given in the question and information contained in the *Reference* to answer the question correctly. Other questions will not require use of this document to arrive at the correct answer.

WHAT ARE THE TEST DETAILS?

When will you take the test?	Number of test questions	Time limit	Results will be available
May - September 2022	80	3 hours	Early Fall 2022
October 2022 and beyond	40	2 hours	Immediately

BEFORE THE TEST

Try to be well rested for the test so you will be alert and efficient. Be sure to bring your test center admission ticket and your current (unexpired) government-issued photo identification (for example, a driver's license). You don't need to bring your *ADAS Composite Vehicle Reference*. It will be available as an electronic pop-up document during the test.

AT THE TEST CENTER

Lockers will be available for you to store personal items that are not allowed in the test room, including cell phones, wallets, and keys. Pencils and scratch paper will be provided to you.

Once the test begins, read each question carefully so that you understand exactly what is being asked. A note at the top of each question will tell you whether or not to use the *Composite Vehicle Reference*. There are no "trick" questions. Each question tests a specific diagnostic skill and has a single correct answer.

If you are unsure of an answer, don't get stuck. Mark the answer that you think is correct and flag the question using the on-screen button. Then go on to the next question. If you answer all questions before the allotted time is up, you can go back to the flagged questions. Answer every question to the best of your ability. **Do not leave any answers blank. Your score is based on the total number of correct answers that you give.**

ADVANCED DRIVER ASSISTANCE SYSTEMS (ADAS) SPECIALIST TEST SPECIFICATIONS & TASK LIST

Content Area	Questions in Test	Percentage of Test
A. General ADAS Service and Diagnosis	14	35%
B. Camera-Based Systems Service and Diagnosis	10	25%
C. RADAR-Based Systems Service and Diagnosis	12	30%
D. Ultrasonic (Sonar)-Based Systems Service and Diagnosis	4	10%
Total	40*	100%

* Note: The L4 test will initially contain 80 questions and allow 3 hours for completion. Test-takers will receive a notice of completion upon finishing the test. In early Fall 2022, the L4 test will take its final form with 40 questions and 2 hours for completion. At that time, score reports will be available for all previous and current test-takers.

A. General ADAS Service and Diagnosis (14 questions)

1. Inspect for damaged, missing, obstructed, modified, customized, inoperative, previously repaired or add-on vehicle components that could affect the performance of an ADAS system (including the use of non-factory specified components).
2. Determine reparability of body components that would affect the operation of an ADAS component.
3. Determine reparability of damaged components and related mounting locations.
4. Research applicable vehicle and service information, such as vehicle service history, service precautions, technical service bulletins, and service campaigns/recalls.
5. Research and identify ADAS intersystem design/configuration action with other vehicle systems (i.e., Braking, Steering, Powertrain, Active Suspension, Restraints, and TPMS).
6. Verify vehicle concern and/or conduct vehicle pre-scan; determine vehicle equipment/options.
7. Use scan tool data, bi-directional controls, freeze frame data and/or diagnostic trouble codes (DTCs) to diagnose electronic systems; interpret readings and determine needed action.
8. Read and interpret electrical schematic diagrams and symbols.
9. Check voltage and voltage drop in electrical/electronic circuits; interpret readings and determine needed action.
10. Check current flow in electrical/electronic circuits; interpret readings and determine needed action.
11. Check continuity and resistances in electrical/electronic circuits and components; interpret readings and determine needed action.
12. Check electronic circuit waveforms; interpret readings and determine needed action

-
13. Inspect, test, and replace components, connectors, terminals, wiring, fusible links, circuit breakers, fuses, diodes, and current limiting devices; determine needed action.
 14. Remove and replace components and modules; program, reprogram, code, initialize, and/or configure as needed.
 15. Diagnose faults and failures in ADAS such as Camera, Radar, Ultrasonic (Sonaar), LiDAR, Infrared, GPS, Head-Up Display, Driver Monitoring Systems, etc.
 16. Diagnose failures in the data bus communications network(s); determine needed action.
 17. Determine root cause of faults.
 18. Identify calibration procedures (dynamic and/or static).
 19. Identify tooling required for calibration; identify proper calibration environment.
 20. Perform component alignment and calibration setup using tape measure, level, laser, square, string and/or plumb bob. Perform conversion of units of measurement (standard, metric, etc.).
 21. Determine the cause(s) of incorrect, incomplete or unsuccessful ADAS calibration; determine needed actions.
 22. Conduct a post-repair vehicle scan. Verify effectiveness of repairs.
 23. Research and identify ADAS components, system design, configuration, and available options.

B. Camera-Based Systems Service and Diagnosis (10 questions)

1. Verify concern and/or vehicle condition; determine if any concerns are part of normal system operation, the result of a malfunction, or the result of a previous service.
2. Inspect and test for missing, obstructed, modified, inoperative, tampered, or previously repaired components.
3. Research system description using technical information to determine system components, locations, and operation. Identify installed vehicle options.
4. Identify system operation using service information; determine diagnostic procedure and whether available information is adequate to proceed with effective diagnosis.
5. Research system to determine the enable criteria for setting and clearing diagnostic trouble codes (DTCs) and warning/malfunction indicator(s).
6. Interpret scan tool data stream, diagnostic trouble codes (DTCs), and freeze frame data to determine system condition.
7. Check electronic circuit waveforms; interpret readings and determine needed action.
8. Inspect, test, repair or replace components, connectors, terminals and wiring.
9. Diagnose failures in data communications bus network(s), determine needed action.
10. Remove and replace components and modules; program, reprogram, code, initialize, and/or configure as needed.
11. Identify need for calibration (dynamic and/or static).
12. Perform calibration setup including proper placement of target(s) as required; perform calibration in accordance with manufacturer specifications.
13. Identify optical axis misalignment and/or interference; identify mounting or structural issues which may impact or affect camera sensor calibration and/or operation; determine needed action.
14. Determine the cause(s) of incorrect, incomplete or unsuccessful system calibration including environmental interference issues; determine needed actions.
15. Verify for accurate calibration, confirm repair, and road test in accordance with vehicle manufacturer procedures.
16. Conduct a post-repair vehicle scan. Verify effectiveness of repairs.

C. RADAR-Based Systems Service and Diagnosis (12 questions)

1. Verify concern and/or vehicle condition; determine if any concerns are part of normal system operation, the result of a malfunction, or the result of a previous service.
2. Inspect and test for missing, obstructed, modified, inoperative, tampered, or previously repaired components.
3. Research system description using service information to determine system components, locations, and operation. Identify installed vehicle options.
4. Identify system operation using service information; determine diagnostic procedure and whether available information is adequate to proceed with effective diagnosis.
5. Research system to determine the enable criteria for setting and clearing diagnostic trouble codes (DTCs) and warning/malfunction indicator(s).

-
6. Interpret scan tool data stream, diagnostic trouble codes (DTCs), and freeze frame data to determine system condition.
 7. Check electronic circuit waveforms; interpret readings and determine needed action.
 8. Inspect, test, repair or replace components, connectors, terminals, and wiring.
 9. Diagnose failures in data communications bus network(s); determine needed action.
 10. Remove and replace components and modules; program, reprogram, code, initialize, and/or configure as needed.
 11. Identify need for calibration (dynamic and/or static); perform calibration setup including proper placement of target(s); perform calibration in accordance with manufacturer specifications.
 12. Identify mechanical alignment, mounting, paint refinishing, body repair, and structural issues which may affect calibration and/or operation; determine needed action.
 13. Determine the cause(s) of incorrect, incomplete or unsuccessful system calibration including environmental interference issues; determine needed actions.
 14. Verify for accurate calibration, confirm repair, and road test in accordance with vehicle manufacturer procedures.
 15. Conduct a post-repair vehicle scan. Verify effectiveness of repairs.

D. Ultrasonic (Sonar)-Based Systems Service and Diagnosis (4 questions)

1. Verify concern and/or vehicle condition; determine if any concerns are part of normal system operation, the result of a malfunction, or the result of a previous service.
2. Inspect and test for missing, obstructed, modified, inoperative, tampered, or previously repaired components.
3. Research system description using service information to determine system components, locations and operation. Identify installed vehicle options.
4. Identify system operation using service information; determine diagnostic procedure and whether available information is adequate to proceed with effective diagnosis.
5. Research system to determine the enable criteria for setting and clearing diagnostic trouble codes (DTCs) and warning/malfunction indicator(s).
6. Interpret scan tool data stream, diagnostic trouble codes (DTCs) and freeze frame data to determine system condition.
7. Check electronic circuit waveforms; interpret readings and determine needed action.
8. Inspect, test, repair or replace components, connectors, terminals and wiring.
9. Diagnose failures in data communications bus network(s), determine needed action.
10. Remove and replace components and modules; program, reprogram, code, initialize, and/or configure as needed.
11. Identify need for calibration (dynamic and/or static); perform calibration setup including proper placement of target(s); perform calibration in accordance with manufacturer specifications.
12. Identify mechanical alignment, mounting, paint refinishing, body repair, and structural issues which may affect ultrasonic sensor calibration and/or operation; determine needed action.
13. Determine the cause(s) of incorrect, incomplete or unsuccessful system calibration including environmental interference issues; determine needed actions.
14. Verify for accurate calibration, confirm repair, and road test in accordance with vehicle manufacturer procedures.
15. Conduct a post-repair vehicle scan. Verify effectiveness of repairs.

ADVANCED DRIVER ASSISTANCE SYSTEMS (ADAS) SPECIALIST TEST SAMPLE QUESTIONS

Questions 1-4 are to be answered without using the *ADAS Composite Vehicle Type 1 Reference*.

1. The DYNAMIC calibration of a forward-facing camera could fail if:
 - (A) the back-up camera lens is dirty.
 - (B) the calibration procedure is attempted on a rainy day.
 - (C) an ultrasonic sensor has a loose electrical connector.
 - (D) the lighting quality is poor in the shop's calibration bay.

Question 1 Explanation

Answer (A) is wrong. A dirty back-up camera lens would cause poor video quality when in use but would not affect the forward-facing camera DYNAMIC calibration..

Answer (B) is correct. Attempting the calibration procedure on a rainy day could cause the forward-facing camera DYNAMIC calibration attempt to fail because the camera view could be obstructed by raindrops..

Answer (C) is wrong. The ultrasonic sensors are used for object detection at slow speeds and would not affect the forward-facing camera DYNAMIC calibration.

Answer (D) is wrong. Poor quality lighting in the service bay would not affect the forward-facing camera DYNAMIC calibration as it is not performed in the service bay.

2. A forward radar module static calibration is being performed.

Technician A says that the windows in the calibration bay should be covered.

Technician B says that floor slope in the calibration bay should be checked.

Who is right?

- | | |
|------------|---------------------|
| (A) A only | (C) Both A and B |
| (B) B only | (D) Neither A nor B |

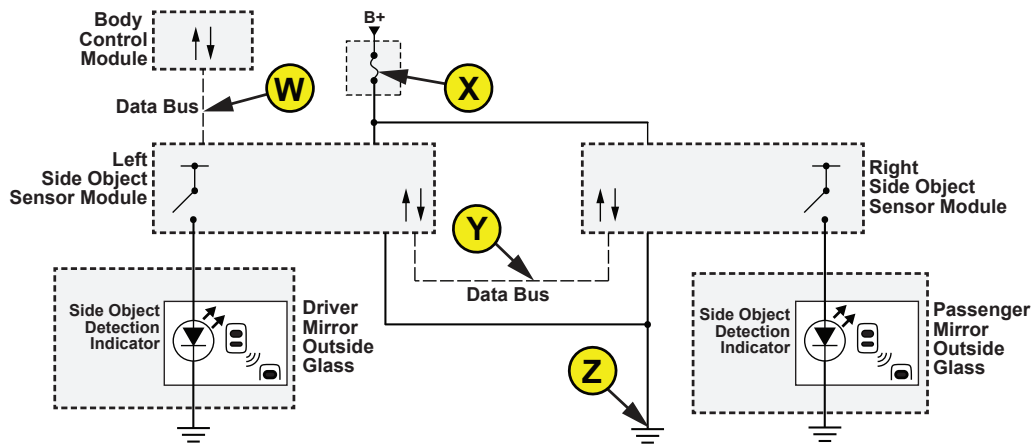

3. The blind spot detection system is inoperative on a vehicle equipped with the system shown. During diagnosis, the technician observes the scan tool cannot communicate with the right-side object sensor module. All other modules communicate properly. The cause could be:
- (A) a short-to-ground at W.
 - (B) an open fuse at X.
 - (C) a short-to-ground at Y.
 - (D) an open circuit at Z.
4. When parking a vehicle equipped with ultrasonic parking sensors, there is no warning when the vehicle gets close to objects. Which of these could be the cause?
- (A) Rain is impairing sensor operation.
 - (B) The vehicle is too close to objects for the ultrasonic sensors to detect.
 - (C) It's too dark outside for the ultrasonic sensors to identify objects.
 - (D) The ultrasonic system has been turned OFF by the driver.

Questions 5-8 require the use of the ADAS Composite Vehicle Type 1 Reference.

5. Multiple ADAS-related systems are inoperative on the composite vehicle. In the gateway module, there are error codes for lack of communication with each of the electronic control modules on the ADAS CAN bus. With the battery disconnected and the ADAS central module unplugged, a DMM is connected between terminals 78 and 79 of the harness side of the connector. The resistance measures 2.3 Ω . Which of these could be the cause?
- (A) An open circuit at gateway module terminal 61
 - (B) A short circuit between engine control module (ECM) terminals 71 and 72
 - (C) A short circuit between surround view camera module terminals 61 and 62
 - (D) An open circuit at right rear corner radar module terminal 84

Question 5 Explanation

With the ADAS central module unplugged and the DMM connected between terminals 78 and 79 of the harness side of the connector, the resistance should measure about 120 Ω .

Answer (A) is wrong. An open circuit at gateway module terminal 61 (ADAS CAN bus) would result in a measurement indicating an infinite resistance (open circuit).

Answer (B) is wrong. A short circuit between engine control module (ECM) terminals 71 and 72 (Vehicle CAN bus) would cause communication faults, but not the ADAS Can bus faults in this scenario.

Answer (C) is correct. A short circuit between surround view camera module terminals 61 and 62 (ADAS Can bus) would cause the resistance measurement indicated on the DMM.

Answer (D) is wrong. An open circuit at right rear corner radar module terminal 84 (Private CAN bus) would cause communication faults, but not the ADAS Can bus faults in this scenario.

6. The blind spot monitor is unable to detect vehicles approaching on the left side of the composite vehicle. During diagnosis, no ADAS-related DTCs are found stored. This could be caused by:

- (A) a lack of ignition switch voltage supply at fuse 22.
- (B) an open circuit at right rear corner radar module terminal 71.
- (C) a poor electrical connection at G207.
- (D) use of excessive amounts of body filler during repair of the rear bumper.

7. Technician A says that the mounting bracket of multifunction forward facing camera is an integral part of the windshield on the composite vehicle.

Technician B says that glass cleaner should be used to clean the camera lens of multifunction forward facing camera on the composite vehicle.

Who is right?

- (A) A only
- (B) B only
- (C) Both A and B
- (D) Neither A nor B

8. On the composite vehicle, which of these is the maximum distance at which a rear corner ultrasonic sensor can detect an object?

- (A) 0 meters
- (B) 0.5 meters
- (C) 2.5 meters
- (D) 5.5 meters

ANSWERS to Sample Questions

1. B 2. B 3. C 4. D 5. C 6. D 7. A 8. D

ADVANCED DRIVER ASSISTANCE SYSTEMS (ADAS) SPECIALIST TEST INDUSTRY TRAINING

The training sources listed in this guide are designed to help you sharpen your technical skills and knowledge regarding advanced driver assistance systems (ADAS). Remember--the more you learn, the better your chances of passing this test.

Please call or write the listed organizations for availability, schedules, and prices. Training resources can also be found on ASE's home page at www.ase.com, the International Automotive Technicians Network (iATN) at www.iatn.net, or the Diagnostic Network at www.diag.net.

ACDelco offers a blended learning approach with instructor-led and web-based training. Advanced driveability training covers OBD II, fuel system diagnostics, emissions control system diagnosis, engine performance, and emerging technologies. For information about training offerings, visit www.acdelco.com/for-professionals/training.html or call ACDelco at (800) 825-5886.

The **ASE Training Manager Council** is a professional organization of individuals responsible for the development and delivery of training in the auto and truck industries. ATMC administers the ASE Accredited Training Provider of Continuing Automotive Service Education program. A list of ASE accredited training providers can be found at the ATMC website: www.atmc.org

Automotive Technician Training Services offers seminars, webinars, and self-study training courses all designed to help technicians stay in touch with the latest driveability and electrical systems diagnostic and repair procedures. Technician-trainers deliver the instructor-led seminars and webinars. Self-study materials deliver information that will both teach, and enhance diagnostic skills. ATTS Training Center, 10 Lupi Plaza, Mahopac, NY 10541 Call: (845) 628-1062. Internet: www.attstraining.com

AVI OnDemand offers video training programs that cover advanced engine performance testing and diagnosis, emissions control system diagnosis, computer controlled ignition systems diagnosis, electrical/electronic systems testing and diagnosis, as well as manufacturer-specific systems. Programs covering the use of scan tools are also offered. Ph: (800) 718-7246. Internet: www.aviondemand.com

CAR-O-Liner is an ASE Accredited Training Provider that focuses on collision repair solutions including ADAS repairs and calibration, Internet: <https://car-o-liner.com/na/>

CARQUEST Technical Institute / WORLDPAAC Training Institute offer training to customers of Advance Auto Parts, WORLDPAAC, CARQUEST, and Autopart International. The CTI development team uses OE information, case studies, and on-vehicle testing to create real-world proprietary content. WTI works directly with OEMs to license content. Many CTI and WTI trainers are factory-trained instructors, technicians, and shop foremen. Internet: www.ctionline.com

Cengage Learning provides training textbooks and online, interactive courseware covering many areas of automotive repair, including a Preparation Guide for the ASE L1 Test. The online interactive computer program is called Technician Test Preparation (TTP). TTP is designed to help prepare technicians for the ASE tests, including L1. For a free catalog, write: Cengage Learning, P.O. Box 8007, Clifton Park, NY 12065, or call (800) 347-7707. Internet: www.trainingbay.cengage.com.

Delphi Product and Service Solutions offers technical training materials and classes with real world applications to today's vehicles. All content has been developed by drawing on experience from working with many different vehicle manufacturers. Training products include textbook and CD-ROM formats covering many different topics in Engine Management, Ignition, and OBD II systems. Instructor led training classes covering a wide range of topics are also available. An overview of all training products and services is available on the website. Internet: www.delphiautoparts.com/toolbox. Phone: (877) 550-TECH.

EAST Training is an ASE Accredited Training Provider that provides in-person comprehensive training programs primarily for the automotive aftermarket. Internet: <https://www.easttraining.com/>

Hunter Engineering Company is an ASE Accredited Training Provider and a world leader in alignment, wheel and tire service, inspection, and ADAS calibration equipment. They provide in-person and online training and support in each area for which they provide equipment. <https://www.hunter.com/>

Motor Age offers *Training for ASE Certification*, a self-study training guide that is updated regularly and contains both technical information and sample questions. For ordering information, write: Motor Age Training, P.O. Box 6310, Duluth, MN 55806. Ph:(800) 240-1968; Internet: www.PassTheASE.com

NAPA Autotech provides a broad self-study curriculum as well as hands-on and seminar style classes. Topics include no-code driveability diagnosis and automotive electrical/electronic diagnosis. To get more information about prices, specific course content, or to order any of these courses, call (800) 292-6428. Internet: www.NAPAAutotech.com

Robert Bosch LLC provides a selection of training aids and reference material for gasoline and diesel fuel injection systems, starting and charging systems, and antilock braking systems on automotive and heavy duty applications. Technical hands-on training is also available. For more information, visit the Bosch site at www.boschtechno.com

Standard Motor Products, Inc. is an accredited training provider that offers professional technician seminars. Their mission statement is: To educate aftermarket automotive technicians on established and emerging technologies via instructor led and online training programs that

enable them to perform accurate, efficient diagnosis and proper vehicle repair. During their classes, the attendee will engage in actual diagnosis using case studies using real data that they can select from captured data obtained in the shop to apply what they've learned. An ASE-Certified professional instructor conducts the seminars with a heavy emphasis on diagnostics and troubleshooting. Each seminar includes a digital workbook (including video and scan data links) for reference after the class. SMP also offers over 200 archived, one-hour long webinars, with additional Spanish offerings. These can be viewed anywhere an internet connection is available, including at home. Internet: <http://standardbrandtraining.com>

VEEJER Enterprises offers training in automotive electrical diagnosis and repair and vehicle electronics troubleshooting. Training programs are designed to teach step-by-step methods used for performing electrical repairs, as well as the skills necessary for troubleshooting electrical and electronic problems. Training programs cover the use of a DMM, current clamp, digital logic probe, scope meter, and dual-trace lab scope when testing and diagnosing electrical and electronic circuits. Training is offered through home-study programs, as well as hands-on instructor led electrical/electronics troubleshooting training workshops. For more information, contact: Veejer Enterprises, 3701 Lariat Lane, Garland, TX 75042-5419, or call (972) 276-9642. Internet: www.veejer.com

ZF is an ASE Accredited Training Provider and one of the largest manufacturers of auto and truck components and parts in the world. They provide in-person and online training for all automotive systems including ADAS. Internet: <https://aftermarket.zf.com/en/aftermarket-portal/for-partners/workshops/zf-protect/zf-protect-country-selection/>



National Institute for
**AUTOMOTIVE
SERVICE
EXCELLENCE**
1503 Edwards Ferry Road, NE
Suite 401
Leesburg, VA 20176

(703) 669-6600 www.ase.com

© 2022 by the
National Institute for
**AUTOMOTIVE
SERVICE
EXCELLENCE**

All rights reserved

ASE Online Resources

**ASE Test Registration Info:
ASE.com/Register**

**Training Resources:
ASE.com/AccreditedTraining**

**ASE Webinars:
YouTube.com/ASEcampus**

**Test Prep, Study Guides, Practice
Tests, Testing Tips and Demos:
ASE.com/TestPrep**

**myASE “How-To” Demos:
ASE.com/myASEdemos**

**ASE Consumer Webpage:
ASE.com/Drivers**

**ASE Store:
ASE.com/Store**



National Institute for
**AUTOMOTIVE
SERVICE
EXCELLENCE**
1503 Edwards Ferry Road, NE
Suite 401
Leesburg, VA 20176

(703) 669-6600 www.ase.com