

THE OFFICIAL ASE STUDY GUIDE

ASE Truck Equipment Tests



National Institute for
**AUTOMOTIVE
SERVICE
EXCELLENCE**

ASE TRUCK EQUIPMENT TESTS

Table of Contents

<i>Overview</i>	3–7
<i>Truck Equipment Tests</i>	8–21
• Truck Equipment Installation and Repair (E1).....	8
• Electrical/Electronic Systems Installation and Repair (E2).....	13
• Auxiliary Power Systems Installation and Repair (E3).....	17
<i>Test Prep & Training</i>	22



COPYRIGHT © 2022 by

National Institute for

AUTOMOTIVE SERVICE EXCELLENCE

All rights reserved

OVERVIEW

Introduction

The Official ASE Study Guide for Truck Equipment Tests is designed to help technicians study for the ASE certification tests. This guide contains detailed information on the content of tests in the Truck Equipment series. The task list for each test, found in the following pages, should help you review your technical knowledge. Your focus should be on less familiar topics. This should make it easier to select additional reference materials that will help you prepare for your test(s).

ASE voluntary certification helps technicians prove their abilities to themselves, to their employers, and to their customers. By passing the tests and submitting appropriate work experience, you will earn the most valuable credential available to truck equipment technicians. Because the tests are challenging, you'll have the satisfaction of knowing you are among the elite in your profession. What's more, these credentials are recognized throughout the U.S.

Certified technicians promote customer trust and improve the image of the industry. And trust and professionalism are the first steps to a better, more prosperous business.

ASE encourages you to take the tests and to join the proven pros who wear the ASE Blue Seal of Excellence.®

How Do I Become Certified?

There are three tests in the Truck Equipment Technician certification series. If you pass one or more test(s) and have at least two years of relevant hands-on work experience, you will become certified as an ASE Truck Equipment Technician. If you pass all three tests in the series and meet the experience requirement, you will earn certification as a Master Truck Equipment Technician.

Your test results will be emailed to you immediately following your testing appointment. Results will not be given over the phone nor will they be released to anyone without your written permission. If you fail a test, you must wait 30 days from the test date before you can purchase it again.

Certification credentials are valid for five years. Recertification ensures certified truck equipment specialists are seen as up-to-date in their profession. If you have been certified in an area for almost five years, it is time to register for the

OVERVIEW (CONTINUED)

corresponding recertification test. Most recertification tests are about half the length of the initial certification tests.

Truck Equipment Tests

This Study Guide contains Test Specifications, Task Lists, and sample questions for the following ASE tests:

- Truck Equipment Installation and Repair (Test E1)
- Electrical/Electronic Systems Installation and Repair (Test E2)
- Auxiliary Power Systems Installation and Repair (Test E3)

ASE also offers certification in areas including Automobile/Light Truck, Maintenance and Light Repair, Medium/Heavy Truck, Transit Bus, School Bus, Collision Repair/Refinish, Parts Specialist, and Advanced Level specialties. Separate study guides are available for those test series.

For full information on ASE testing as well as downloadable Study Guides and other test preparation resources, visit www.ase.com.

Who Writes the Questions?

Working professionals from the service industry with expertise in the test topic write the questions, which are entirely job-related. The questions are designed to test the skills that you need to know in installing and servicing truck equipment. Theoretical knowledge is not covered.

Each question has its roots in an ASE “item-writing” workshop where service representatives from truck equipment manufacturers, aftermarket parts and equipment manufacturers, working technicians, and technical educators get together to share ideas and translate them into test questions. Each test question written must survive review by all members of the group. The questions are written to mirror practical problems relevant to the installation, diagnosis, and repair performed by technicians in their day-to-day work.

After being written, all questions are pre-tested and quality-checked on a national sample of technicians. Those questions meeting ASE standards of quality and accuracy are then included in scored sections of the tests; those that do not are redrafted or discarded altogether.

How Do I Prepare for the ASE Tests?

The most important thing you can do is become familiar with test content and question formats.

OVERVIEW (CONTINUED)

How Long are the Tests?

Truck Equipment Tests		Certification Tests		Recertification Tests	
	Name	Number of questions	Testing time	Number of questions	Testing time
E1	Truck Equipment Installation & Repair	55*	1.25 hrs	23	30 mins
E2	Electrical / Electronic Systems	60*	1.25 hrs	25	30 mins
E3	Auxiliary Power Systems	55*	1.25 hrs	23	30 mins

* ASE certification tests include 10 research questions that are not counted for score. Since you don't know which questions those are, you need to answer every question. You must have passed the corresponding certification test once to be eligible for the shorter recertification test.

The Test Specifications in this booklet describe the content covered by each test. The Task Lists detail the actual work performed by technicians in each specialty area. Together, these are the blueprint for writing and assembling the ASE tests.

Each question on the test is related to a particular task or set of tasks in the task list. Therefore, review the task lists, thinking about whether you know how to perform each task listed.

All questions are multiple-choice. The sample questions in this Study Guide are examples of the five types of questions on the test. Note there are different instructions for some question types.

Read each question carefully so that you understand exactly what is being asked. Each question tests a specific diagnostic or repair problem and has only one correct answer.

To summarize, we suggest the following steps be taken:

- Step 1.** Carefully read the Test Specifications for each test you will attempt.
- Step 2.** Study the Task List for each area.
- Step 3.** Go over the sample questions to become familiar with each question type. This is very important!
- Step 4.** Review steps 1 through 3 and identify the skill areas where you need additional study.

OVERVIEW (CONTINUED)

Getting Started

Registration information is available at www.ase.com. This site shows testing locations and provides other important information, including an electronic version of all ASE Study Guides.

While on the ASE website, take a moment to create your own myASE account (if you do not already have one), which will allow you to register for tests, make test appointments, and have direct access to all your personal ASE certification information. Should you have questions that the website does not answer, you can reach our helpful customer service staff at contactus@ase.com or 800-390-6789.

Bring--

- ✓ Admission Ticket
- ✓ Current Government Issued Photo ID

Leave in locker--

- ✓ Books
- ✓ Calculator
- ✓ Coat
- ✓ Cell Phone
- ✓ Smart Devices
- ✓ Wallet
- ✓ Keys

At the Test Center—Some Tips

Try to be well rested on exam day. Allow extra time to find parking and the Test Center office. Late arrivals may be turned away by Test Center staff. If you cannot take a test because you are late, you will forfeit your test fees.

Bring your Admission Ticket and unexpired, government-issued photo ID with you. Books, notes, calculators, and electronic devices (including cell phones) will not be permitted in the test room. You will be assigned a locker to store personal items. Most test centers have airport-level security procedures for all candidates, so be prepared for “wandering” or other security checks.

You will receive scratch paper and pencils, and for certain advanced level tests, a printed reference booklet. Each test appointment begins with a short tutorial on the operation of the testing platform. You may also preview the platform online at www.ase.com/free-test-drive before you arrive at the Test Center.

Each test has a time limit, as listed in the chart on page 5. After you start your test, the computer screen will continuously display the amount of time left. If you finish early, you can either review your answers or end the test and continue to the next test (if you are taking more than one). Once you submit a test for scoring, you cannot go back and review it. If you are taking several tests and need a short break, take it between tests. Take your break when you reach the

OVERVIEW (CONTINUED)

screen that asks if you are taking additional tests. Do not take a break during your test as the test clock will continue to run.

If a question is difficult, mark the answer that you think is correct and flag the question using the on-screen button. Then go on to the next question. When you have finished the test, you may have time to go back to the flagged questions. Your score is based on the number of correct answers, so you should try to answer every question.

When you finish your last test, you will be given a short customer satisfaction survey. After you complete the survey, inform the staff and leave. When you check your email, your test results will be waiting for you! If you need a paper copy right away, ask the staff to print your results before you leave the test center.

Test Content and Sample Questions

To help you prepare, each section begins with the Test Specifications, which will list the main categories covered and the number of test questions, as well as the percentage of the test devoted to each topic.

The Task List describes the work activities a technician should be able to perform. This list was developed by working technicians and technical experts from across the country and will provide a valuable checklist telling you what you should know for the test.

The number of tasks listed does not equal the number of questions. Although every question relates to at least one listed task, some tasks may not appear on the test. Some complex tasks may be covered by several questions. Some questions may cover multiple simple tasks. The main goal of the list is to describe what is done on the job; any task on the list **may be** covered on the test.

Sample questions follow the Task List. Although these specific questions will not appear on tests, they are in the same format as actual test questions. The ASE tests employ several types of multiple-choice questions. Note that some questions have special instructions; the same instructions will appear with similar questions on the ASE tests. ■

TEST SPECIFICATIONS AND TASK LIST

TRUCK EQUIPMENT INSTALLATION AND REPAIR (TEST E1)

Content Area	Questions in Test	Percentage of Test
A. Frame Preparation	11	25%
B. Suspension Systems	5	11%
1. Preparation and Installation (3)		
2. Inspection and Repair (2)		
C. Driveshaft Preparation and Installation	5	11%
D. Body and Equipment	24	53%
1. Preparation (8)		
2. Installation and Repair (16)		
Total	45	100%

NOTE: All tasks should be completed following original equipment manufacturers' (OEM) and/or component manufacturers' recommended practices.

A. Frame Preparation (11 questions)

1. Verify wheelbase (WB), cab-to-axle (CA)/cab-to-trunnion (CT) measurements and tandem axle spread.
2. Verify gross vehicle weight rating (GVWR) and gross axle weight ratings (GAWR).
3. Verify frame width, height, and length.
4. Determine body/equipment layout locations.
5. Relocate and/or modify frame-mounted vehicle components/systems as necessary.
6. Repair, lengthen, shorten or reinforce frame and frame members.
7. Lay out mounting holes; select appropriate tools.
8. Prepare vehicle if welding.
9. Inspect frame and frame members for damage (such as: cracks, breaks, distortion, elongated holes, looseness, and corrosion); determine needed repairs.
10. Inspect, install, or repair frame, hangers, brackets, and crossmembers.

B. Suspension Systems (5 questions)

1. Preparation and Installation (3 questions)

1. Relocate suspension components as necessary.
2. Determine additional auxiliary axle location(s) and install.
3. Install additional suspension components including leaf springs, air bags, stabilizers (torsion bars), stop blocks, spacer blocks, tanks, and valves/controls.
4. Check driveshaft clearances to moving and stationary components under operating conditions.

E1 TASK LIST (CONTINUED)

5. Verify proper routing and support of air lines, fluid lines, control cables, and electrical harnesses; modify as necessary.
6. Attach axle to suspension seats, as necessary.

2. Inspection and Repair (2 questions)

NOTE: Tasks 1 through 10 apply to used chassis components and should be accomplished as necessary.

1. Inspect and replace front axles, U-bolts, and nuts.
2. Inspect, service, adjust, or replace king pin, steering knuckle bushings, locks, bearings, seals, and covers.
3. Inspect, service, and replace shock absorbers, bushings, brackets, and mounts.
4. Inspect, repair, or replace components of leaf spring suspensions.
5. Inspect, adjust, or replace torque arms, bushings, and mounts.
6. Inspect, adjust, or replace axle aligning devices such as radius rods, track bars, stabilizer bars, and related components.
7. Inspect, repair, or replace components of walking beam suspensions.
8. Inspect, test, adjust, repair, or replace air suspension pressure regulator and height control valves, lines, hoses, and fittings.
9. Inspect, test, repair, or replace components of air bag suspension systems.
10. Measure vehicle ride height; determine needed adjustments or repairs.

C. Driveshaft Preparation (5 questions)

1. Lay out driveshaft; determine required driveshaft length.
2. Inspect driveshaft for proper phasing.
3. Install driveshaft; measure and adjust operating angles (loaded and unloaded) where applicable.
4. Lubricate universal joints and splines.
5. Inspect, service, or replace driveshaft and related components; properly phase yokes.
6. Inspect, repair, and replace driveshaft center support bearings and mounts.

D. Body and Equipment (24 questions)

1. Preparation (8 questions)

1. Verify body/equipment mounting location on vehicle.
2. Select and install proper body spacers as necessary; confirm body height.
3. Lay out body and equipment mounting holes; select appropriate tools.
4. Identify fastener type, grade, diameter, and length.
5. Select appropriate cutting/welding tools and equipment; perform cutting and welding procedures.

2. Installation and Repair (16 questions)

1. Fabricate and install subframes as required.
2. Install body, equipment, and/or related components; torque fasteners as required.
3. Determine layout, install, connect, and test all federally required lighting and reflector systems.
4. Install fuel and diesel exhaust fluid (DEF) fill tubes (if applicable).
5. Determine layout and install rear end or impact protection.
6. Construct and install appropriate guards and shields.

E1 TASK LIST (CONTINUED)

7. Connect auxiliary HVAC.
8. Furnish and install informational, operational, and safety labels in appropriate locations; provide manuals as required.
9. Verify that proper required certification labels are attached.
10. Remove and reinstall park assist sensors and camera. ■

SAMPLE QUESTIONS

TRUCK EQUIPMENT INSTALLATION AND REPAIR (TEST E1)

1. The correct placement of a suspension load pressure air gauge is:
(A) before the air control switch.
* (B) after the pressure regulator.
(C) before the pressure regulator.
(D) before the pilot valve.

2. Who certifies that an “incomplete” straight truck is a “completed vehicle”?
* (A) The final stage manufacturer
(B) The chassis manufacturer
(C) The intermediate stage manufacturer
(D) The body manufacturer

3. When installing a van body on a medium or heavy-duty chassis, the front U-bolt should be located:
* (A) as close to the front of the body as possible.
(B) behind the first crossmember.
(C) no closer than 18 in. (45.7 cm) from the front of the body.
(D) in front of the first crossmember.

4. An air lift axle raises too slowly.
Technician A says that a failed quick release valve could be the cause.
Technician B says that poor suspension lubrication could be the cause.
Who is right?
* (A) A only
(B) B only
(C) Both A and B
(D) Neither A nor B

E1 SAMPLE QUESTIONS (CONTINUED)

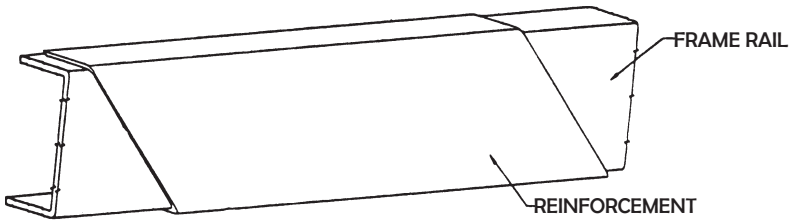

5. When installing a full channel frame reinforcement on the mild steel chassis frame shown in the illustration, the best technique is to:
- * (A) circular fillet weld the web of the reinforcement to the chassis frame.
 - (B) skip weld around the outside of the reinforcement.
 - (C) MIG weld completely around the outside of the reinforcement.
 - (D) weld the reinforcement to the top and bottom chassis frame flanges.
6. The desired angle of the hanger bearing in relation to the driveshaft should be:
- (A) 1 - 2°
 - (B) 3 - 4°
 - (C) 45°
 - * (D) 90°

This question contains the word EXCEPT. Read the question carefully before choosing your answer.

7. Each of these dimensions is needed to determine the required body mount U-bolt length, EXCEPT the:
- (A) frame depth.
 - (B) long sill depth.
 - (C) depth of the spacer.
 - * (D) depth of the crossmember.

TEST SPECIFICATIONS AND TASK LIST ELECTRICAL/ELECTRONIC SYSTEMS INSTALLATION AND REPAIR (TEST E2)

Content Area	Questions in Test	Percentage of Test
A. General Electrical Diagnosis	12	24%
B. Battery System	5	10%
C. Auxiliary Electric Power Units	9	18%
D. Charging Systems	4	8%
E. Lighting Systems	9	18%
F. Associated Electrical Circuits and Components	11	22%
Total	50	100%

A. General Electrical Diagnosis (12 questions)

1. Identify, interpret, and locate circuit components using schematic, circuit, and component locator diagrams.
2. Understand basic electrical/electronic concepts and high-voltage safety issues.
3. Check continuity in electrical/electronic circuits using appropriate test equipment.
4. Check applied voltages, circuit voltages, and voltage drops in electrical/electronic circuits using appropriate test equipment.
5. Check current flow in electrical/electronic circuits and components using appropriate test equipment.
6. Check resistance in electrical/electronic circuits and components using appropriate test equipment.
7. Locate and repair shorts, grounds, and opens in electrical/electronic circuits.
8. Diagnose key-off (parasitic) battery drain problems.
9. Install, inspect, test, and replace fusible links, circuit breakers, fuse blocks, and fuses.
10. Install, inspect, test, and replace diodes and printed circuits/control modules.
11. Install, inspect, test, and replace relays and solenoids.
12. Determine correct power connection point or distribution center.

B. Battery System (5 questions)

1. Perform battery state-of-charge test.
2. Perform battery capacity (load, high-rate discharge) test and determine needed service.
3. Install, inspect, clean, service, or replace battery, terminal connections, and cables.
4. Install, inspect, clean, repair, or replace battery boxes, mounts, and hold-downs.
5. Charge battery using appropriate method for battery type.
6. Jump-start vehicle using jumper cables and a booster battery or auxiliary power supply.

E2 TASK LIST (CONTINUED)

7. Determine correct auxiliary battery-type application and location.
8. Install auxiliary battery, diodes, and isolator system.

C. Auxiliary Electric Power Units (9 questions)

1. Perform current draw tests.
2. Perform voltage drop tests.
3. Install, inspect, and repair auxiliary AC/DC electric power unit, modules, relays, solenoids, switches, sensors, circuit protection devices, wiring, and connectors.
4. Install, inspect and repair shore power systems, circuit protection devices, wiring, and connectors.

D. Charging Systems (4 questions)

1. Inspect, adjust, and replace alternator drive belts, pulleys, tensioners, fans, and mounting brackets.
2. Perform charging system voltage and amperage output tests.
3. Perform charging circuit voltage drop tests; determine needed repairs.
4. Remove, replace, and/or add an alternator; check pulley alignment.
5. Inspect, repair, or replace charging system connectors and wires.
6. Inspect, repair, and/or replace on-board auxiliary battery charging systems.

E. Lighting Systems (9 questions)

1. Diagnose the cause of brighter-than-normal, intermittent, dim, or no lamp operation.
2. Install, test, aim, and replace headlights and auxiliary lighting systems.
3. Test, repair, or replace headlight switches, wires, connectors, terminals, sockets, relays, modules, and miscellaneous components.
4. Install, inspect, test, repair, or replace switches, bulbs/LED, sockets, connectors, terminals, relays, modules, resistors, and wires of parking, clearance, and taillight circuits on trucks and trailers.
5. Install, inspect, test, adjust, repair, or replace stoplight circuit switches, bulbs/LED, sockets, connectors, terminals, relays, modules, and wires.
6. Install, inspect, test, repair, or replace turn signal and hazard circuit flashers, switches, bulbs/LED, resistors, sockets, connectors, terminals, relays, modules, and wires.
7. Install, inspect, test, adjust, repair, or replace back-up light and warning device circuit switches, bulbs/LED, resistors, sockets, horns, buzzers, connectors, terminals, modules, and wires.

F. Associated Electrical Circuits and Components (11 questions)

1. Install, inspect, test, repair, or replace warning devices, interlocks, alarms, inverters, switches, relays, connectors, terminals, wires, sensors, and modules.
2. Inspect, test, repair or replace electro-magnetic clutches, motors, and related resistors, relays, switches, sensors, controls, modules, connectors, terminals, and wires.
3. Determine power and ground source(s) (chassis interface) provided by original equipment manufacturer (OEM) for auxiliary equipment connections.
4. Install, test, replace or repair chassis/trailer connection devices. ■

SAMPLE QUESTIONS

ELECTRICAL/ELECTRONIC SYSTEMS

INSTALLATION AND REPAIR (TEST E2)

1. A bed cap (topper) being installed on a pickup body does not have a center, high-mounted stop lamp (CHMSL). The truck, itself, is equipped with a CHMSL.

Technician A says that a CHMSL is required if the vehicle gross weight rating is 10,000 lbs or less.

Technician B says that CHMSL is required if the vehicle is over 80 inches (203 cm) wide.

Who is right?

- * (A) A only
(B) B only
(C) Both A and B
(D) Neither A nor B

2. A technician finds that when the liftgate is operated, there is a 2-volt drop between the liftgate motor and the battery. Which of these could be the cause?

- (A) Current draw from the motor is low.
(B) The supply cable gauge is too large.
(C) The battery state-of-charge is low.

- * (D) The supply cable gauge is too small.

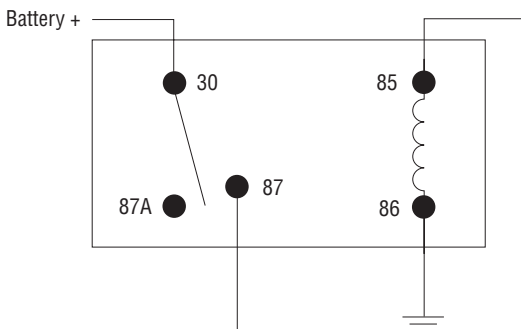

3. At which of the relay terminals shown would a technician check for a high current load when the relay is energized?

- (A) 85
(B) 86
* (C) 87
(D) 87A

E2 SAMPLE QUESTIONS (CONTINUED)

4. The “body up” indicator lamp does not function. Technician A says that an open switch could be the cause. Technician B says that a corroded connector could be the cause. Who is right?
- (A) A only
(B) B only
* (C) Both A and B
(D) Neither A nor B
5. When performing a battery capacity (load, high-rate discharge) test on a 900 CCA battery, the load applied should be:
- (A) 300 amps.
* (B) 450 amps.
(C) 600 amps.
(D) 900 amps.

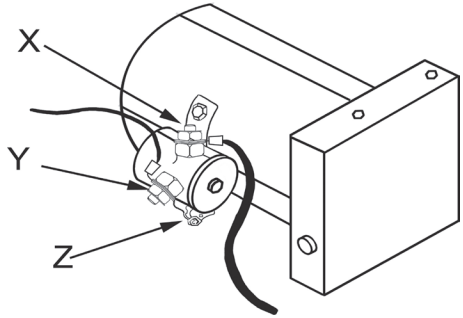

6. The liftgate motor shown in the illustration will not run when the circuit is energized. Battery voltage is present at terminals X and Y. To diagnose the problem, a jumper cable is installed across terminals X and Z. Technician A says that if the motor runs with the jumper cable installed, the motor solenoid could be the cause. Technician B says that if the motor does not run with the jumper cable installed, a bad ground could be the cause. Who is right?
- (A) A only
(B) B only
* (C) Both A and B
(D) Neither A nor B

This question contains the word EXCEPT. Read the question carefully before choosing your answer.

7. Warning lights and buzzers can be switched through any of these EXCEPT a:
- (A) power switch.
(B) grounding switch.
(C) relay.
* (D) diode.

TEST SPECIFICATIONS AND TASK LIST

AUXILIARY POWER SYSTEMS INSTALLATION AND REPAIR (TEST E3)

Content Area	Questions in Test	Percentage of Test
A. Hydraulic Systems	30	67%
1. Pumps (8)		
2. Filtration/Reservoirs (Tanks) (5)		
3. Hoses, Fittings, and Connections (4)		
4. Control Valves (2)		
5. Actuators (3)		
6. General System Operation (8)		
B. Mechanical Systems	13	29%
C. Pneumatic Systems	2	4%
Total	45	100%

A. Hydraulic Systems (30 questions)

1. Pumps (8 questions)

1. Determine pump type and rotation.
2. Install pump properly to include spline lubrication, brackets/supports, location, driveshaft angles, slip joint location(s), case drain, and hydraulic connections.
3. Diagnose causes of unusual pump noises, temperatures, and flow; determine needed repairs.
4. Verify proper fluid application.

2. Filtration/Reservoirs (Tanks) (5 questions)

1. Identify type of filtration system; verify filter application and flow direction.
2. Install filter(s) in proper locations(s); flush system in accordance with manufacturers' recommendations.
3. Diagnose cause(s) of system contamination.
4. Service filters and breathers in accordance with manufacturers' recommendations.
5. Install reservoirs/tanks, related components, and shut off valves in accordance with recommended procedures; flush and clean as required.

3. Hoses, Fittings, and Connections (4 questions)

1. Identify proper applications to include sizes, types, and pressure/flow/temperature ratings.
2. Determine hydraulic layout (length, size, routing, bend radii, and heat, abrasion, or line of sight protection).
3. Determine correct application of thread sealants.

E3 TASK LIST (CONTINUED)

4. Assemble hoses/tubing, connectors, and fittings in accordance with manufacturers' specifications; use proper procedures to avoid contamination.
5. Diagnose cause of component leakage.

4. Control Valves (2 questions)

1. Identify control valves (directional and accessory) application and porting.
2. Install valves in accordance with recommended procedures regarding location, mounting, and shielding; verify flow direction.
3. Verify system operating pressure and flow; confirm component compatibility.
4. Verify, install, and adjust valve controls (electrical, mechanical, and pneumatic).

5. Actuators (3 questions)

1. Purge/bleed system in accordance with recommended procedures.
2. Diagnose the cause of incorrect actuator movement; determine needed repair.
3. Diagnose the cause of seal failure; determine needed repair.
4. Identify hydraulic motor type and rotation.
5. Verify case drain operation (where applicable).
6. Identify cylinder type (single or double acting).

6. General System Operation (8 questions)

1. Interpret system diagrams, schematics, and layouts.
2. Identify proper tools for installation, diagnosis, maintenance, and repair.
3. Perform general service diagnosis and repair procedures.
4. Assemble and integrate system components.
5. Perform periodic inspection and maintenance on systems.

B. Mechanical Systems (13 questions)

1. Verify PTO type, location, and mounting clearance; remove cover and identify PTO drive gear location and compatibility with PTO.
2. Install supplied gaskets, verify correct fasteners and lock tabs; install PTO, torque to specifications.
3. Remove, where applicable, PTO shifter cover and measure backlash with dial indicator; adjust as needed.
4. Install lubrication line, if required.
5. Install shift controls (electrical, mechanical, and pneumatic).
6. Refill transmission to proper lubrication level with transmission manufacturer's recommended lubricant.
7. Test operation of PTO; check for unusual noises and leaks; check shifter operation.
8. Verify proper rotational direction of output shaft.
9. Install all warning and operational labels.
10. Determine PTO driveshaft length, application, and operating angles.
11. Install PTO driveshaft; lubricate U-joints and slip joints; check that operating angles are within manufacturers' recommended specifications.
12. Check for proper PTO shaft timing (phasing).
13. Check belt tension and alignment of belt driven components. Check clutch air gap adjustment (if applicable); verify proper electrical connections, and test operation.
14. Diagnose the causes of vibrations in auxiliary power trains.

E3 TASK LIST (CONTINUED)

15. Test operation of PTO speed controls.
16. Install guarding, if required.
17. Diagnose the cause of abnormal PTO/component wear.

C. Pneumatic Systems (2 questions)

1. Determine proper location for pressure protection valve(s); install valve(s), and check operation.
2. Determine proper location for the air activated control valve(s).
3. Connect DOT specified lines, fittings, and hoses to air activated control valve(s); determine proper routing of air hoses.
4. Verify operation of pressure reducing (air regulator) valve(s). ■

SAMPLE QUESTIONS

AUXILIARY POWER SYSTEMS INSTALLATION AND REPAIR (TEST E3)

1. Which of these is the correct hydraulic hose to install on the suction side of the hydraulic pump?
- (A) A one-braided wire hydraulic hose
 - (B) A two-braided wire hydraulic hose
 - * (C) A one-spiral wire hydraulic hose
 - (D) A two-spiral wire hydraulic hose

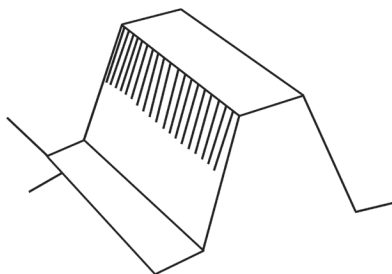

2. The gear wear at the shaded area of a gear tooth shown in the illustration is caused by:
- (A) the PTO gear being installed too tight to the transmission gear.
 - * (B) the PTO gear being installed too far away from the transmission gear.
 - (C) disengaging the PTO under load.
 - (D) engaging the PTO improperly.
3. A cylinder head packing is leaking.
Technician A says that nicks on the cylinder rod could be the cause.
Technician B says that a rolled over V packing could be the cause.
Who is right?
- (A) A only
 - (B) B only
 - (C) Both A and B
 - * (D) Neither A nor B

E3 SAMPLE QUESTIONS (CONTINUED)

4. A 3-way valve is used with:
- * (A) a single acting cylinder.
 - (B) a double acting cylinder.
 - (C) an intensifying cylinder.
 - (D) a snowplow reversing cylinder.

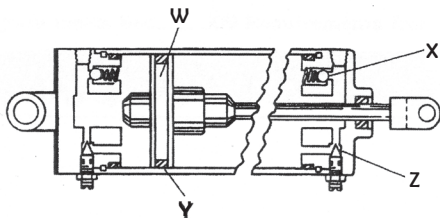

5. In the illustration shown, which of these is the piston seal?
- (A) W
 - (B) X
 - * (C) Y
 - (D) Z

This question contains the word EXCEPT. Read the question carefully before choosing your answer.

6. Small bits and pieces of rubber are found throughout a hydraulic system. Any of these could be the source EXCEPT the:
- (A) inner lining of the hydraulic hoses.
 - * (B) pump shaft seal.
 - (C) fitting O-rings.
 - (D) valve spool seal.

TEST PREP & TRAINING

Taking an ASE certification test doesn't have to be a high stress challenge. The ASE website contains test preparation and training information tailored to your specific needs. Visit www.ase.com and use the "Test Prep & Training" tab. We've loaded this section of our website with plenty of information to help boost both your knowledge and your confidence—two of your most important tools as a test-taker.

Official ASE Practice Tests

The easy way to try your hand at taking ASE-style certification exams, without the stress and high stakes of the real thing. www.ase.com/official-ase-practice-test-program.

Study Guides

Free, step-by-step guides to help you understand what's involved in each test—including sample questions and suggestions for further preparation. www.ase.com/ase-study-guides.

ASE Testing Demo

Are you new to ASE testing or has it been a few years? The demonstration at www.ase.com/free-test-drive will show you how the test platform works, so you'll feel right at home with the testing format.

In-service Training Providers

You can choose from a variety of training programs, both instructor-led and self-directed, that have been evaluated through a quality-assurance process and verified as ASE accredited training providers.

Community Colleges and Technical Training Schools

Get instructor-led, hands-on training at schools accredited by the ASE Education Foundation.

ATMC for more training options

The ASE Training Managers Council is a professional organization of individuals responsible for the development and delivery of training in the auto and truck industries. The ATMC administers the ASE Accredited Training Provider of Continuing Automotive Service Education program. A list of ASE accredited training providers can be found at www.atmc.org.

Other test prep and training programs

Many test-takers have used aftermarket test prep and training programs and found them helpful. Please note that ASE has neither reviewed nor approved the content of these programs and providers.



National Institute for

AUTOMOTIVE SERVICE EXCELLENCE

1503 Edwards Ferry Road, NE

Suite 401

Leesburg, VA 20176

To contact us:

703-669-6600

www.ase.com